

Mechanical Multiple Disc Clutches & Brakes



Models MMS & MMD

THE MAXITORQ ADVANTAGES

- *Highest torque in the smallest space.*
- *Simplicity of design allows for wide range of adaptability.*
- *Exclusive Maxitorq "Floating Disc Pacs" prevent drag, abrasion and heat build-up in neutral and provide consistent release.*
- *Positive engagement/disengagement at any speed.*
- *All units may be run in oil or dry applications.*
- *Easy on-line manual adjustment allows fine tuning of the machine.*

HIGH PERFORMANCE, LONG LIFE

Carlyle Johnson MAXITORQ Mechanical Multiple Disc Clutches and Brakes provide 3 to 6 times the torque produced by single plate clutches and brakes making them the ideal solution for high torque, limited space requirements. The entire MAXITORQ line of Carlyle Johnson clutches and brakes incorporate long wearing multiple disc clutch plates. The clutch plates feature a bronze or steel friction surface for added life, superior consistency for indexing and excellent torque transmitting characteristics.

SIMPLICITY OF DESIGN, EASILY ADAPTED & ADJUSTED

The MAXITORQ clutch is completely assembled and shipped ready to slip onto a shaft. Wave springs are used between each pair of inner discs. They spread the discs axially such that a space is maintained between all discs when the unit is in neutral. These separator springs provide the advantage of truly floating discs, which ensures that there is negligible drag, no abrasion, and consequently no heat being generated when the clutch is in neutral.

A locking plate on the disc end of each unit (two on the double types) locks all discs against compression developed by the lever system. Manual adjustment is made by temporarily loosening the lock screw on the split type adjusting ring then turning the ring to give the desired shifting pressure. Only an allen wrench is required for this adjustment.

Standard MAXITORQ Clutches are available in single and double types. Capacities are 1 HP to 150 HP and can be run dry or in oil.

MAXITORQ DRIVING CUPS

Carlyle Johnson MAXITORQ Driving Cups are designed to provide an economical means of adapting the clutch to various types of driven or driving members. Cups are made to precise specifications and hardened for long life.

Driving Cups are available in two styles. The Internal Flange Driving Cups are smaller in outside diameter and provide a lower inertia, whereas the Ring Type Driving Cups enclose the multiple discs, thereby helping to prevent entry of dust, dirt or other harmful material into the mechanism as well as presenting a neat, compact appearance.

SPECIAL APPLICATIONS ENGINEERING ASSISTANCE

MAXITORQ Clutches may be used for a wide variety of applications. Combinations of several types are often used to control speeds, feeds and reversing mechanisms in a single piece of equipment. Typical examples of applications are machine tools, packaging equipment, bottle labeling, printing, knitting/textiles, asphalt pavers and farm machinery, and medical imaging equipment.

At Carlyle Johnson specials are our standard. A significant portion of Carlyle Johnson's production is devoted to the design and manufacture of special clutches, brakes and integrated systems which meet specific user requirements. Carlyle Johnson engineers are readily available to provide assistance for the solution of power control problems, with recommendations for the best applications of MAXITORQ Clutches. Do not hesitate to ask for this service at any time.

MECHANICAL MULTIPLE DISC CLUTCHES

Typical Applications

Cut-Off Coupling

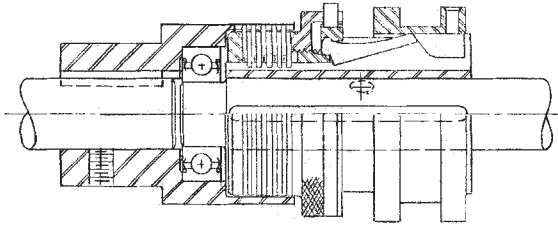

Single Clutch with Flange Cup and V-Belt Pulley

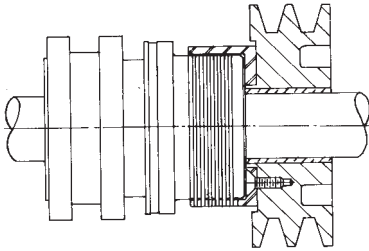

Double Clutch - Driving and Brake

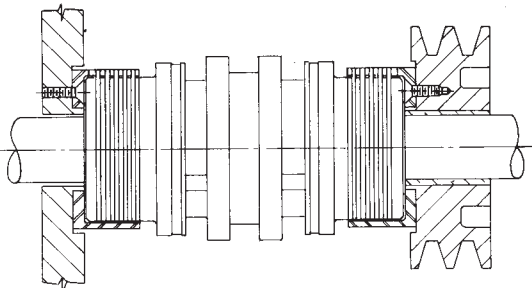

Double Clutch - High and Low Speed Spur Gears

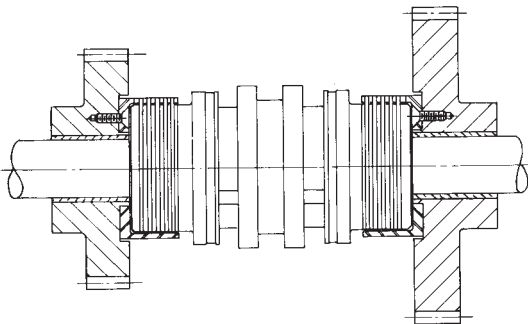

REPLACEMENT PARTS

Every MAXITORQ clutch, brake, or torque limiter is designed to permit rapid, easy replacement of normal wear parts, without the use of special tools. Parts may be obtained for any MAXITORQ product by specifying the part number, clutch size, and serial number.

Mechanical Multiple Disc Replacement Parts

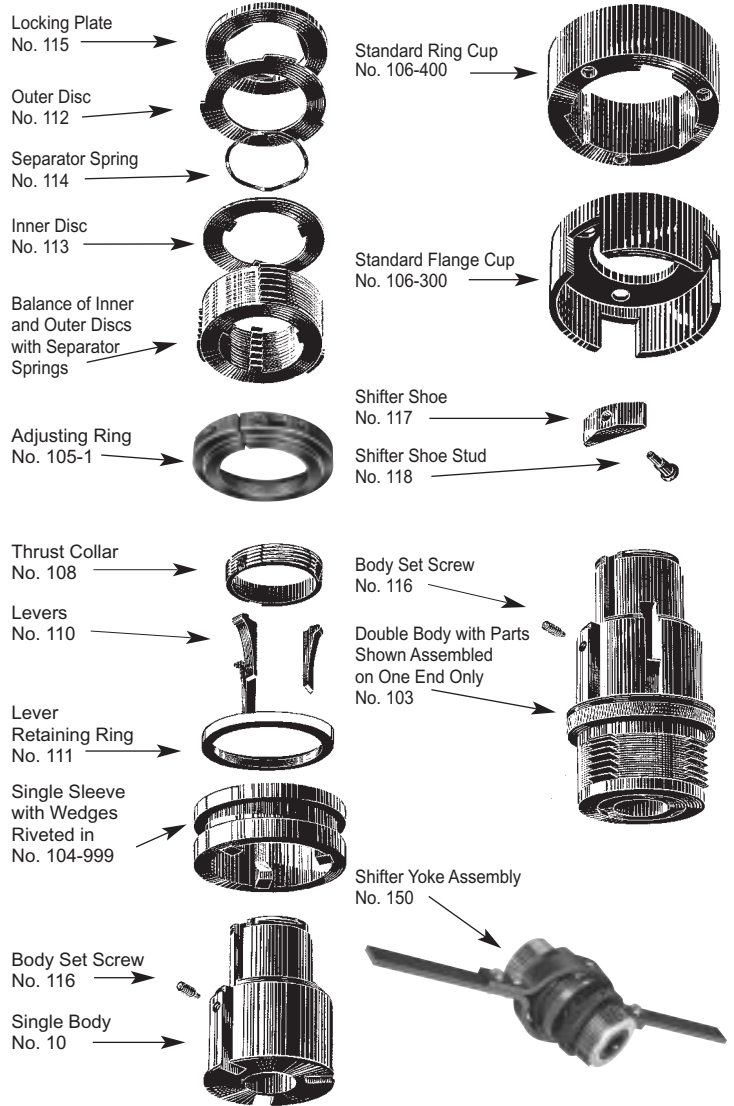

NOTE: MAXITORQ Clutches and brakes as furnished can run dry or in oil. We specifically recommend Series A oils. If high gear loading or worm and wheels are adjacent to the clutch and indicate extreme pressure additives that would reduce clutch torque, please contact the factory for recommendations.

SPECIFICATIONS...SINGLE & DOUBLE MECHANICALLY ACTUATED CLUTCHES & BRAKES

Single

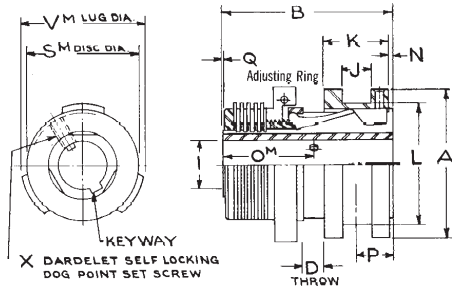

Double

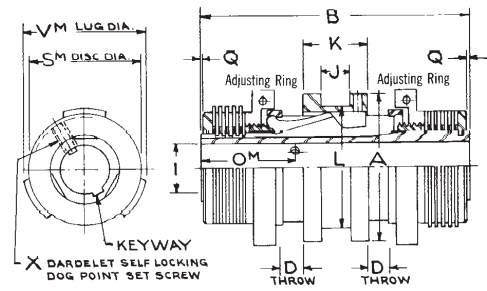

Clutch No.	HP@ 100 RPM	Torque (ft/lbs)		Axial Sleeve Pressure (lbs)	I		Keyway	No. Disc Lugs	A		B		D	J	K	L	N	O ^m	P	Q	S ^m	V ^m	X*
		Dyn.	Stat.		Sngl	Sngl			Dbl	Sngl & Dbl	Sngl & Dbl	Sngl & Dbl											
20**	.100	5	10	15	1/2	5/8	***	3	2.594	2.375	-	.375	.375	.855	2.125	.063	1.313	.563	.125	1.984	2.188	***	
21	.250	13	26	20	3/4	7/8	3/16 X 3/32	3	2.594	3.000	4.750	.375	.500	1.125	2.125	.063	1.641	.625	.024	1.984	2.188	5/16-18	
22	.500	27	54	30	1	1 1/8	3/16 X 3/32	3	3.188	3.469	5.531	.438	.500	1.281	2.625	.063	1.938	.703	.016	2.484	2.750	5/16-18	
23	1.000	53	106	30	1 1/4	1 3/8	1/4 X 1/8	3	3.938	4.031	6.469	.531	.625	1.469	3.125	.063	2.266	.797	.016	3.234	3.563	7/16-16	
24	1.750	92	184	40	1 1/2	1 5/8	5/16 X 5/32	3	4.250	4.031	6.469	.531	.625	1.469	3.563	.063	2.266	.797	.016	3.734	4.063	7/16-16	
25	3.000	158	316	60	1 3/4	1 7/8	3/8 X 3/16	8	4.938	4.813	7.719	.609	.750	1.719	4.063	.094	2.719	.953	.031	4.484	4.875	7/16-16	
26	5.000	263	526	80	2	2 1/4	7/16 X 7/32	12	5.469	5.000	8.094	.609	.750	1.719	4.625	.094	2.906	.953	.031	5.484	5.875	7/16-16	
27	10.000	525	1050	105	2 1/2	2 3/4	9/16 X 9/32	12	7.469	6.344	10.438	.875	.812	2.063	6.500	.094	3.750	1.125	.031	6.984	7.500	7/16-16	
28	15.000	788	1576	150	2 3/4	3	9/16 X 9/32	12	8.625	6.563	10.875	.875	.812	2.063	7.500	.094	3.989	1.125	.031	7.984	8.500	7/16-16	

* Dardélet self-locking full dog point set screw must bottom in spotted hole in shaft. **Single clutch only. ***No. 20 clutch uses 3/16" roll pin in place of set screw and keyway. No. 20 clutch is not a stock item.

Internal Flange Type Driving Cup

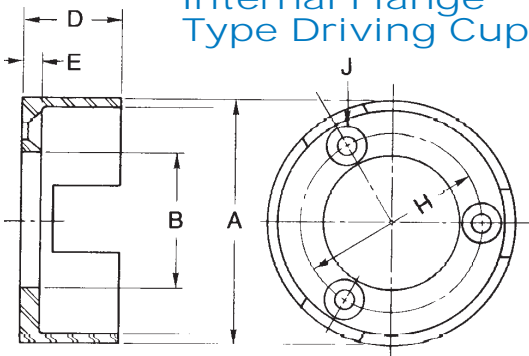

Internal Drive Cup #	A	B	D	E	H	J*	# of mtg holes	# of slots
MMS-0021-106-300	2.188	1.033 1.031	1.031	.188	1.500	8	3	3
MMS-0022-106-300	2.750	1.4395 1.4375	1.250	.188	1.938	10	3	3
MMS-0023-106-300	3.563	1.9395 1.9375	1.406	.250	2.563	1/4	3	3
MMS-0024-106-300	4.063	2.0645 2.0625	1.438	.281	2.875	5/16	3	3
MMS-0025-106-300	4.875	2.5645 2.5625	1.719	.313	3.500	3/16	5	8
MMS-0026-106-300	5.875	3.627 3.625	1.906	.313	4.500	5/16	5	12
MMS-0027-106-300	7.500	4.753 4.750	2.313	.313	5.813	7/16	5	12
MMS-0028-106-300	8.500	5.753 5.750	2.500	.313	6.813	7/16	6	12

* FI

Ring Type Driving Cup

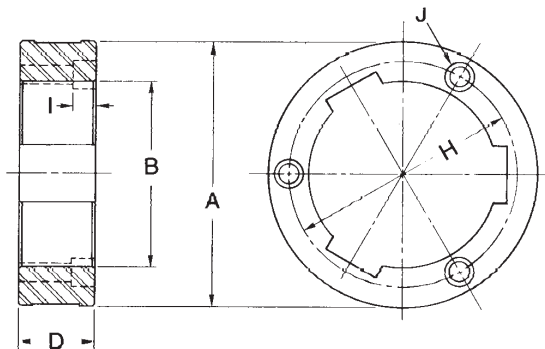

Ring Drive Cup #	A	B	D	H	I	J*	# of mtg holes	# of slots
MMS-0020-106-400	3.123 3.125	2.015 2.017	.688	2.563	.343	1/4	3	3
MMS-0021-106-400	3.123 3.125	2.015 2.017	1.031	2.563	.343	1/4	3	3
MMS-0022-106-400	3.623 3.625	2.515 2.517	1.156	3.063	.343	1/4	3	3
MMS-0023-106-400	4.623 4.625	3.265 3.267	1.313	3.938	.406	5/16	3	3
MMS-0024-106-400	5.123 5.125	3.765 3.767	1.313	4.438	.410	5/16	3	3
MMS-0025-106-400	6.123 6.125	4.515 4.517	1.594	5.313	.531	3/8	4	8
MMS-0026-106-400	7.120 7.125	5.515 5.517	1.781	6.250	.531	3/8	6	12
MMS-0027-106-400	9.120 9.125	7.015 7.017	2.188	8.063	.690	1/2	6	12
MMS-0028-106-400	10.120 10.125	8.015 8.017	2.438	9.063	.680	1/2	6	12

* Cap screw size.



THE CARLYLE JOHNSON MACHINE COMPANY, LLC

POSITIVE ENERGY IN MOTION

291 Boston Turnpike, P.O. Box 9546, Bolton, CT 06043
Tel: 860-643-1531 • Fax: 860-646-2645 • email: maxitorq@cjmco.com
Toll Free: 888-629-4867