

Zero Backlash Jaw Clutches and Brakes

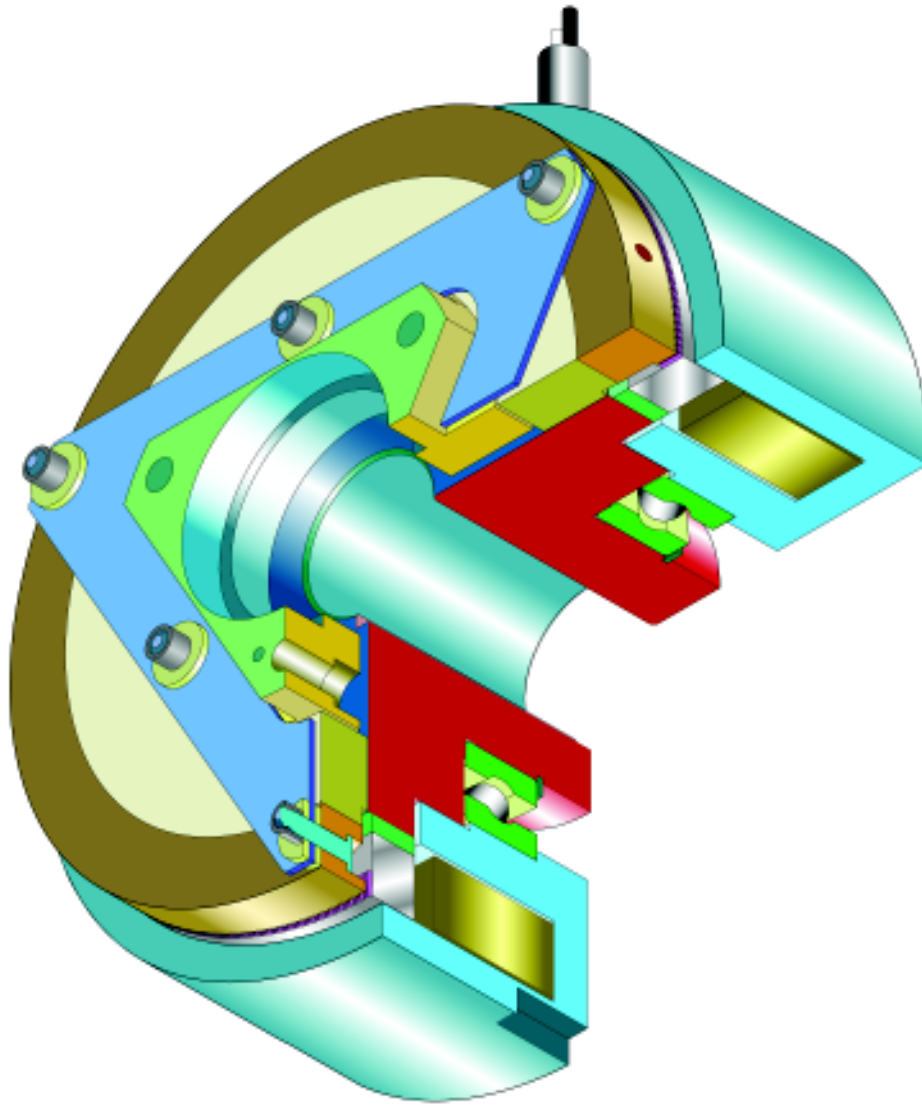

THE MAXITORQ® ADVANTAGE

- Continuous rotor connection provides zero backlash*
- Drag-free neutral. No torque transmitted in the disengaged mode
- Bi-directional operation
- Available in single or multiple position registration for timed applications
- Available as spring set/electrically released for positioning and holding
- Operates in wet or dry applications
- Full rated torque from 10 to 2000 lb. ft.

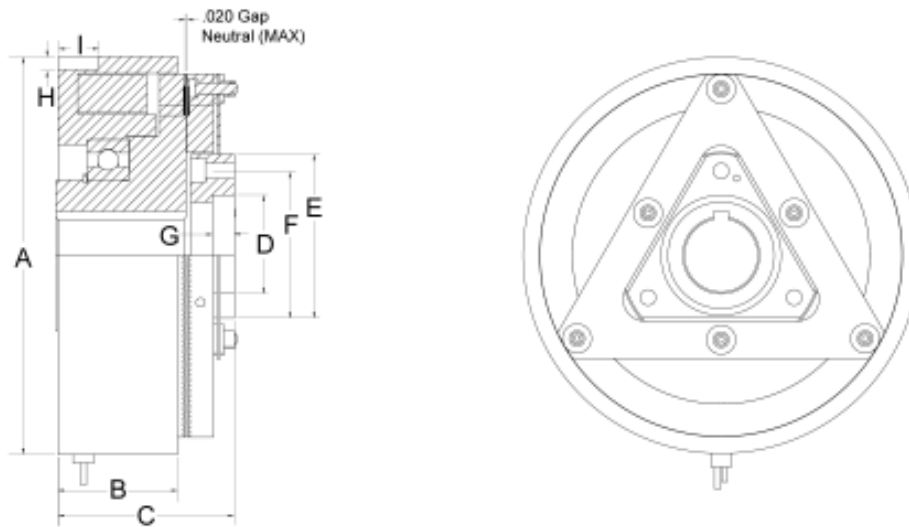

SPECIFICATIONS

Model No.	Torque Lb-Ft	Engagement (Max RPM)	Running (Max RPM)	Number of Teeth	Standard Bore	Keyway	Voltage ⁺ DC ± 10%	Watts	Inertia (Lb-Ft/sec ²)	
									Clutch	Adapter
JEM0375	50	100	5,000	360 or 560	3/4 or 7/8	3/16x 3/32	24 or 100	40	0.0080	0.0060
JEM0425	100	100	5,000	360 or 560	1 or 1 1/8	3/16x 3/32	24 or 100	40	0.0180	0.0011
JEM0475	200	100	5,000	360 or 560	1 1/4 or 1 3/8	1/4 x 1/8	24 or 100	50	0.0032	0.0018
JEM0625	400	100	4,200	360 or 560	1 3/4 or 1 7/8	3/8 x 3/16	24 or 100	60	0.0118	0.0064
JEM0800	800	100	3,600	360 or 560	2 or 2 1/4	7/16 x 7/32	24 or 100	80	0.0350	0.0182

+ - Other voltages are available. Carlyle Johnson stocks coils with voltages ranging from 12 to 240 volts DC.

* - Since there is some compliance in all mechanical systems, no clutch can deliver absolute zero backlash. Carlyle Johnson offers a standard clutch with backlash of less than .001° at 10% of rated torque.

FEATURES / DIMENSIONS

Model No.	A	B	C	ID Pilot D	OD Pilot E	Bolt Circle F	Bolt Size (Qty 3)	G	H	I
JEM0375	4.046	1.350	1.827	1.031/1.032	2.061/2.062	1.547	#10	0.120	0.100	0.375
JEM0425	4.625	1.566	2.562	1.281/1.282	2.354/2.355	1.812	#10	0.160	0.140	0.425
JEM0475	5.187	1.822	2.812	1.531/1.532	2.650/2.651	2.092	1/4	0.200	0.180	0.500
JEM0625	6.750	2.082	3.375	2.031/2.032	3.436/2.437	2.625	1/4	0.250	0.220	0.690
JEM0800	8.500	2.411	3.750	2.401/2.402	4.325/4.326	3.625	3/8	0.250	0.250	0.750

MAXITORQ[®] Zero Backlash* Jaw Clutches and Brakes are designed to optimize size and space in your application. They are ideally suited for positioning and holding, indexing, and maintaining positive registration between an input and output shaft.

Carlyle Johnson has almost 100 years' experience in producing high quality clutches and brakes. Our clutch knowledge and capability to respond to customer requirements is known throughout the industry. We offer a full-time engineering staff to assist you with new applications and in solving power transmission problems. We provide clutches, brakes, and power take-off packages for defense, commercial and military aircraft, space applications, medical equipment, packaging machinery, oil exploration, power generation, printing machinery, and machine tools. This knowledge and ability in producing special solutions for difficult applications is available to you. Simply contact us and ask for help.



A Custom Zero Backlash Positioning Brake used in Medical Imaging



291 Boston Turnpike - P O Box 9546 - Bolton, Connecticut 06043-9546
 (860) 643-1531 • FAX (860) 646-2645 • TOLL FREE (888) 629-4867 • www.cjmco.com