

# Spring Applied Multiple Disc Electric Clutches & Brakes



**Model FEA**

## THE MAXITORQ® ADVANTAGES

- *Highly repetitive, spring-set clutches or brake.*
- *Unique end-plate design allows easy torque adjustment.*
- *Stationary field eliminates brushes, rings.*
- *Highest torque in smallest space.*
- *Stationary cylinder assembly.*
- *No levers, cams, or highly stressed parts.*
- *Long-life floating discs for low heat and extremely low neutral drag.*

### INSTANT RESPONSE, POSITIVE ACTION

MAXITORQ® Fail-Safe Clutches and Brakes offer a solution to the long-sought need for a reliable, automatic, remote-controlled, positive acting clutch to quickly start machinery. Precision designed and manufactured, these units have been thoroughly tested and deliver proven, dependable performance in many diverse applications from heavy-duty machine tools to fragile-product production machinery.

When used as a clutch, the MAXITORQ® Fail-Safe unit will provide a positive, quick acting means of power transmission in a wide range of applications. With its controlled features, the MAXITORQ® Fail-Safe Brake or Clutch is ideally suited to built-in applications in both individual machine units and automated production equipment.

Because of its compactness, simplicity, and reliable performance, the MAXITORQ® Fail-Safe Brake satisfies the vital need for an automatic, remote-controlled unit which will protect personnel from accidents and machines from expensive damage.

### SIMPLE, FOOLPROOF OPERATION

MAXITORQ® Fail-Safe Clutches and Brakes are simple and have few moving parts. Electrically operated, the coil winding is sealed within a stationary housing which is supported on anti-friction bearings. A powerful electromagnetic force disengages a multiple

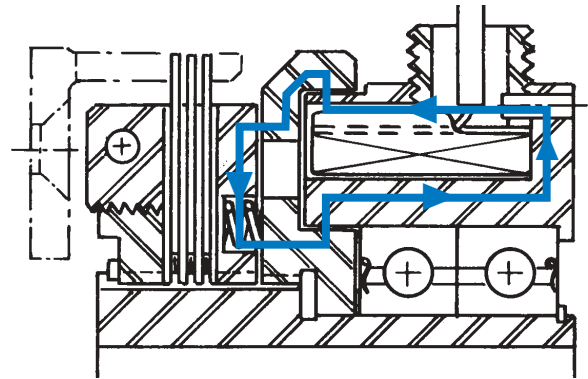

*Radial Magnetic Flux Path provides maximum torque throughout life of clutch.*

disc unit to provide a low drag neutral. There are no stressed parts either on or off, and since the coil/housing assembly does not rotate, there are no slip rings, brushes, or troublesome wiring problems.

When energized, the coil induces a strong magnetic flux in our exclusive radial flux design to flow in the path shown by arrows in the accompanying drawing. This magnetic force flows through the buttress plate across the Fail-Safe air gap through the armature to override the spring loaded pressure on the multiple disc unit. When the coil is not energized, radially spaced coil springs between the buttress plate and the armature maintain a constant pressure on the multiple disc unit and, depending upon application, provide a positive spring loaded clutch, brake or drive. Separator springs between the friction discs assure fast disc separation and a low drag neutral.

# SERIES 9000A FAIL-SAFE ELECTRIC CLUTCHES

## EASILY INSTALLED, ADJUSTABLE

MAXITORQ® Fail-Safe Clutches or Brakes feature an adjustable end plate design. In a typical brake installation, the Fail-Safe unit is keyed to a shaft and engages with a stationary cup which is usually secured to a machine frame. The coil is energized and disengages the armature plate, separating the multiple friction discs for release. Actuation of the Fail-Safe Brake is by means of a limit switch, overload sensor, or similar electric apparatus wired in series with the coil winding. When trouble occurs, the sensing device interrupts the electrical circuit, de-energizing the coil, allowing the coil springs to compress the multiple friction discs thereby braking the machine to a stop or coupling the driving and driven members as a clutch.

The adjustable multiple disc unit will provide long service and can be rebuilt without special tools. The coil housing is kept from rotating by either electrical conduit or a fixed member fastened to the threaded fitting.

## SPECIAL HIGH-PERFORMANCE DESIGNS

Clutches described in this catalog are Carlyle Johnson's standard models. However, a significant portion of Carlyle Johnson's production is devoted to the design and manufacture of special clutches and brakes which meet user specific requirements. For instance, high performance clutches producing higher torques are developed by varying the disc pack design, by using special coils and by modifying the magnetic circuits. Various electric controls are available from Carlyle Johnson which provide faster actuation and controlled acceleration and deceleration.

At the heart of our product is our engineering expertise, which is available to aid you with your motion control needs. Carlyle Johnson engineers are ready and available to provide assistance with recommendations well beyond the clutch itself. Do not hesitate to ask for this service at any time.

## FEA Electric Clutch Replacement Parts

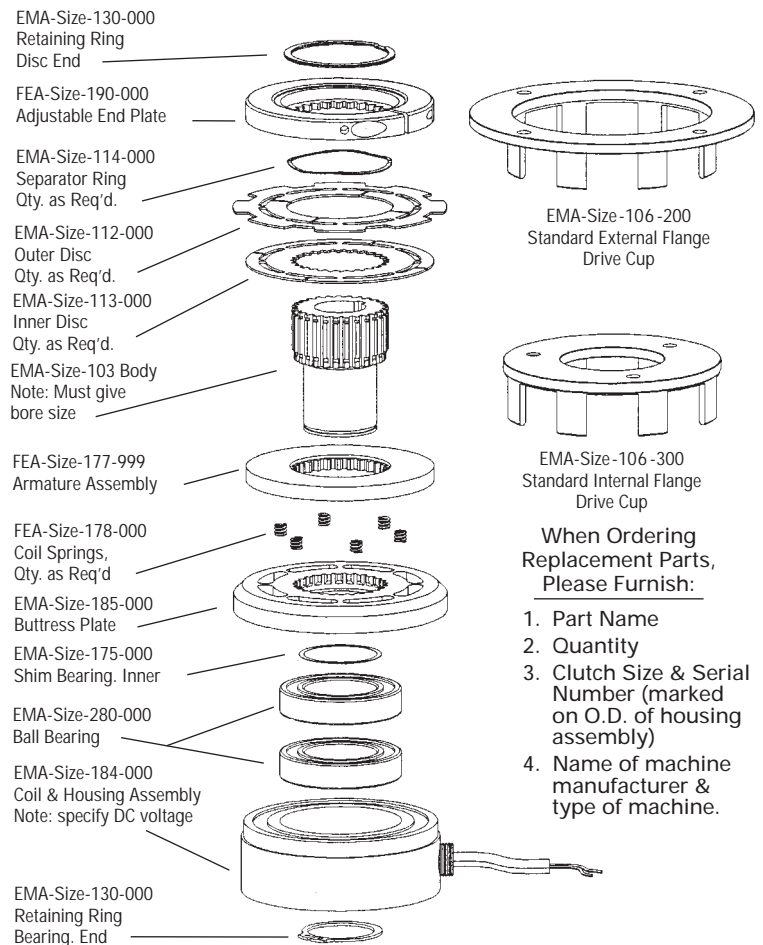

When Ordering Replacement Parts, Please Furnish:

1. Part Name
2. Quantity
3. Clutch Size & Serial Number (marked on O.D. of housing assembly)
4. Name of machine manufacturer & type of machine.

**NOTE: MAXITORQ® Clutches and brakes as furnished can run dry or in oil. We specifically recommend Series A oils. If extreme pressure additives that would reduce clutch torque are utilized, please contact the factory for recommendations.**

# SPECIFICATIONS FEA MAXITORQ® ELECTRIC FAIL-SAFE BRAKES

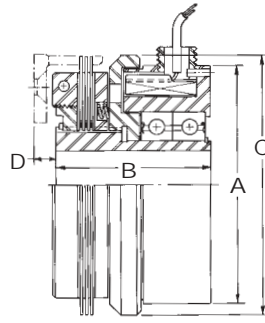
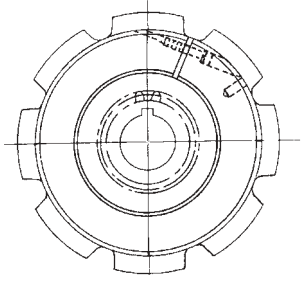

CLUTCH NUMBER	Torque (LB.FT.)		A	B	C	AXIAL POSITION MIN. D	BORES	KEYWAY	D.C.* VOLTS	WATTS
	DYN.	STATIC								
FEA-0375	6	12	3.79688	2.56250	4.06250	.37500	3/4 or 7/8	3/16 X 3/32	100 or 24	40
FEA-0425	12	25	4.35938	2.75000	4.62500	.31250	1 or 1 1/8	3/16 X 3/32	100 or 24	40
FEA-0475	25	50	4.82813	3.06250	5.18750	.43750	1 1/4 or 1 3/8	1/4 X 1/8	100 or 24	50
FEA-0625	50	100	6.35938	3.62500	6.75000	.50000	1 3/4 or 1 7/8	3/8 X 3/16	100 or 24	50
FEA-0800	120	240	8.09375	4.06250	8.50000	.50000	2 or 2 1/4	7/16 X 1/32	100 or 24	80

NOTE: Old Part Designation was FEMA. \*ALL FAIL-SAFE COILS WILL OPERATE AT RATED VOLTAGE ± 10%.

## Internal Flange

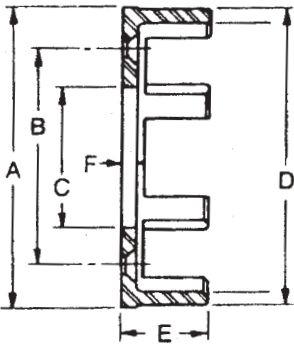

DRIVE CUP #	A	B (b.c.)	Screw Size	# of Holes	C	D	E	F	# of Slots
EMA-0375-106-30	4.250 4.248	3.067 3.057	1/4	3	2.017 2.015	4.188	1.188	.188	8
EMA-0425-106-30	4.750 4.748	3.630 3.620	1/4	3	2.517 2.515	4.688	1.250	.188	8
EMA-0475-106-30	5.250 5.248	3.942 3.932	5/16	3	2.517 2.515	5.188	1.375	.250	8
EMA-0625-106-30	6.812 6.810	5.317 5.307	3/8	4	3.767 3.765	6.750	1.656	.313	8
EMA-0800-106-30	8.562 8.560	6.255 6.245	1/2	4	4.517 4.515	8.500	1.703	.313	12
EMA-0950-106-30	10.062 10.060	8.067 8.057	1/2	4	5.517 5.515	10.00	1.781	.313	12
EMA-1150-106-30	11.812 11.809	9.817 9.807	1/2	6	8.017 8.015	11.75	2	.313	12

**ELECTRIC CLUTCH CUPS** These standard hardened MAXITORQ® Clutch Cups are designed especially for use with Electric Clutches and Brakes. Available with internal or external flanges and provided with mounting bolt holes, these cups can be quickly adapted to various types of driven or driving members. We offer these cups as an economical and simple way of adapting our clutches and brakes to your conditions.

## External Flange

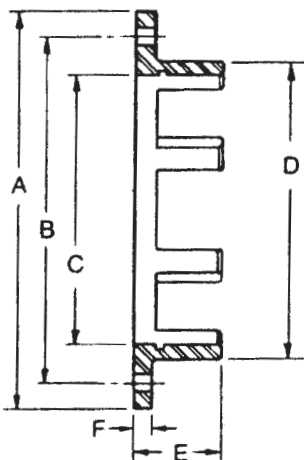

DRIVE CUP #	A	B (b.c.)	Screw Size	# of Holes	C	D	E	F	# of Slots
EMA-0375-106-20	5.625 5.623	4.880 4.870	1/4	3	3.814 3.812	4.188	1.188	.250	8
EMA-0425-106-20	6.125 6.123	5.380 5.370	1/4	4	4.314 4.312	4.688	1.250	.250	8
EMA-0475-106-20	6.875 6.873	6.005 5.995	5/16	4	4.814 4.812	5.188	1.375	.250	8
EMA-0625-106-20	8.500 8.498	7.692 7.982	3/8	4	6.377 6.375	6.750	1.656	.313	8
EMA-0800-106-20	10.625 10.623	9.630 9.620	1/2	4	8.095 8.093	8.500	1.781	.313	12
EMA-0950-106-20	12.250 12.248	11.130 11.120	1/2	4	9.533 9.531	10.00	1.781	.313	12
EMA-1150-106-20	14.248 14.247	13.005 12.995	1/2	6	11.253 11.250	11.75	2	.375	12

NOTE: External Flange Cup for Model FEA 0265 available upon request.



[www.carlylejohnson.com](http://www.carlylejohnson.com)