

Electric Multiple Disc Clutches & Brakes



Model EMA

THE MAXITORQ ADVANTAGES

- *Highest torque in the smallest space.*
- *Exclusive Maxitorq Floating Disc Pacs for lowest drag, consistent release.*
- *Through-the-disc magnetic flux path.*
- *Self adjusting for wear.*
- *Positive engagement/disengagement at any speed.*
- *Stationary field eliminates brushes, rings.*
- *All clutches operate in oil or dry applications.*
- *Computer designed magnetic flux circuits.*

SUPERIOR PERFORMANCE, PROVEN RELIABILITY

Carlyle Johnson MAXITORQ Multiple Disc Electric Clutches deliver 3 to 6 times the torque of single disc electric clutches of the same package size. Where high torque is required and available space is limited, Carlyle Johnson clutches provide superior performance and reliability. They are incorporated into a wide variety of products servicing the medical, machine tool, aircraft/aerospace and food packaging machinery.

Carlyle Johnson electric clutches provide high reliability for critical military applications, as in the U.S. Army's new fighting vehicles, winch mechanisms aboard rescue helicopters, cooling pump drives, bomb hoists, and deicing equipment.

There are sound reasons why Carlyle Johnson is the leading designer and manufacturer of electric multiple disc clutches used worldwide. The heart of those clutches is Carlyle Johnson's proprietary floating-disc-pack which has been used for many years in MAXITORQ clutches. This time-tested design, plus new developments in materials, and our highly efficient magnetic flux circuits, are the basis for Carlyle Johnson's leadership.

SIMPLE, SELF-ADJUSTING EASILY INSTALLED

Construction of the MAXITORQ Multiple Disc Electric clutch is simple and rugged. It is fully self-adjusting in operation up to the point of replacement of friction discs after long service. As with all MAXITORQ clutches, this is easily done without special tools. The coil housing, supported on dual ball bearings, is stationary and is held from rotating by electrical conduit or fixed member engaging the threaded fitting. There are no slip rings or brushes. Since the clutch is a complete, compact, self-contained unit, it is ideally suited to "built-in" installations.

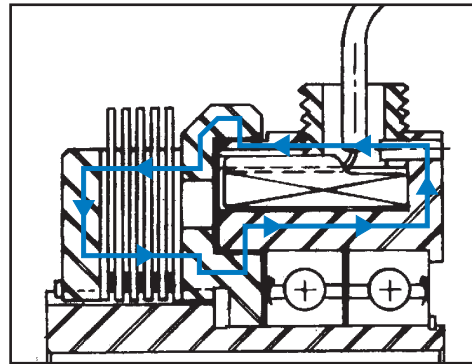

Through-the-Disc Magnetic Flux Path provides maximum torque, automatic wear compensation, and consistent torque throughout life of clutch.

SPECIAL HIGH-PERFORMANCE DESIGNS

At Carlyle Johnson specials are our standard. A significant portion of Carlyle Johnson's production is devoted to the design and manufacture of special clutches, brakes and integrated systems which meet specific user requirements. For instance, high performance clutches producing higher torques are developed by varying the disc pack design, by using special coils and by modifying the magnetic circuits. Various electric controls are available from Carlyle Johnson which provide faster actuation and release and controlled acceleration and deceleration.

At the heart of our product is our engineering expertise, and this expertise is available to assist in your motion control problems. Carlyle Johnson engineers are ready and available to provide assistance with recommendations well beyond the clutch itself. Do not hesitate to ask for this service at any time.

ELECTRIC MULTIPLE DISC CLUTCHES

Typical Applications

Clutch

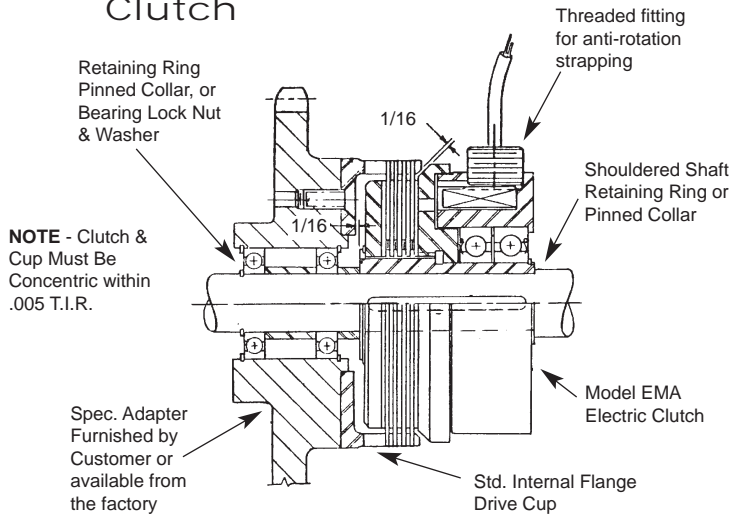

Brake

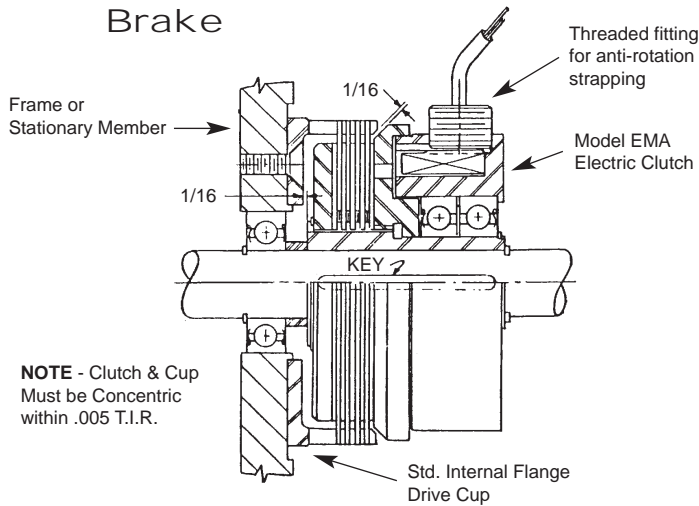

Cut-Off Coupling

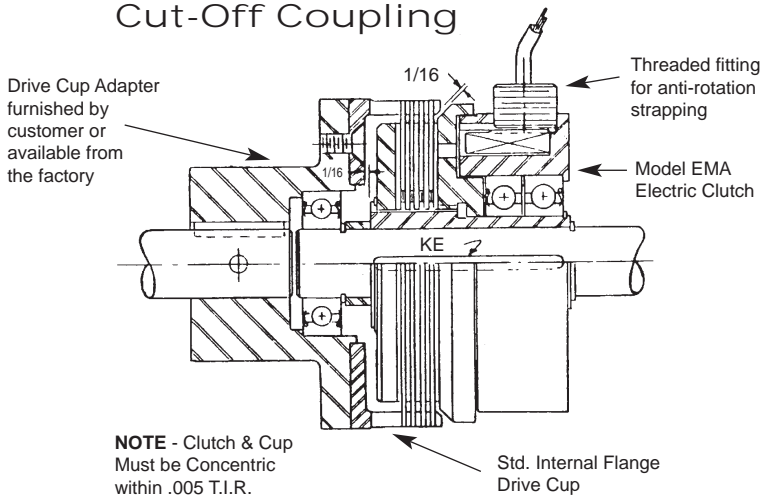

HOW THE ELECTRIC CLUTCH WORKS

The principle of operation is quite simple. The clutch is engaged when the DC coil is energized; the entire assembly of armature plate, inner and outer discs is pulled together and held by magnetic flux passing through it. When the coil is de-energized, the MAXITORQ disc separators instantly separate the discs by breaking the residual magnetism. The result is a positive engagement and a positive disengagement. The high efficiency and dependability of the magnetic system are the result of a patented design of armature, friction discs and buttress plate assembly which assure superior performance.

Model EMA Electric Clutch Replacement Parts

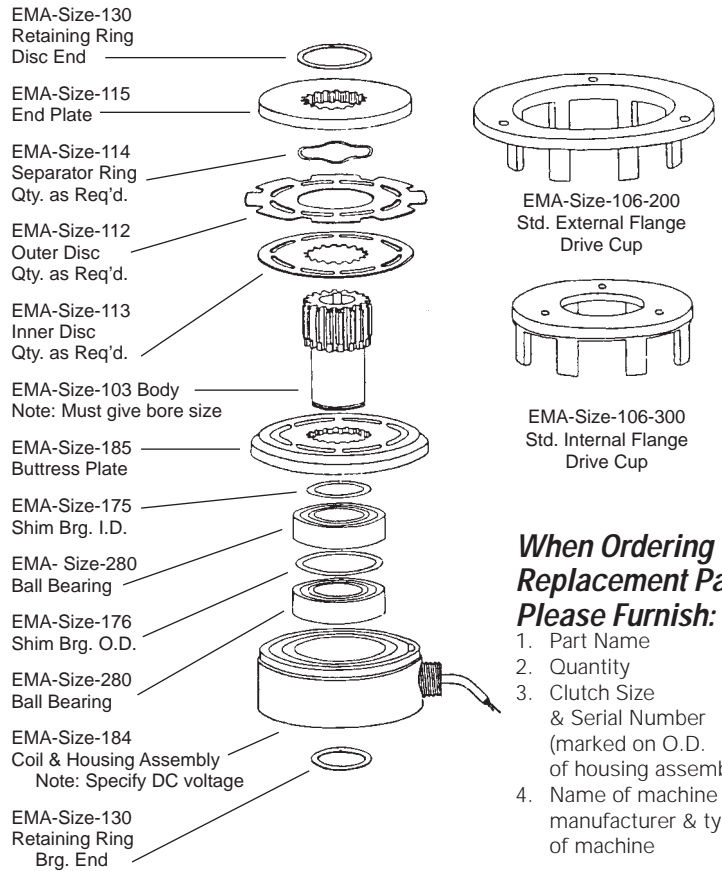

When Ordering Replacement Parts, Please Furnish:

1. Part Name
2. Quantity
3. Clutch Size & Serial Number (marked on O.D. of housing assembly)
4. Name of machine manufacturer & type of machine

NOTE: MAXITORQ Clutches and brakes as furnished can run dry or in oil. We specifically recommend Series A oils. If high gear loading or worm and wheels are adjacent to the clutch and indicate extreme pressure additives that would reduce clutch torque, please contact the factory for recommendations.

SPECIFICATIONS...MAXITORQ ELECTRIC CLUTCHES

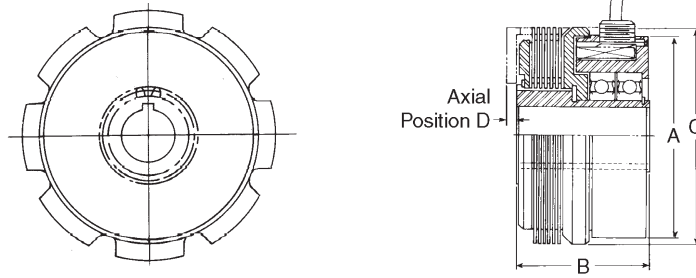

* Clutch SIZE	Torque (LB. FT.)		A	B	C	MIN. D	BORES	KEYWAY	D.C.* VOLTS	WATTS
	DYN.	STATIC								
EMA-0265	8	15	2.625	2.156	2.781	.188	1/2 or 5/8	1/8 x 1/16	100 or 24	40
EMA-0325	8	15	2.266	2.344	3.516	.25	1/2 or 5/8	1/8 x 1/16	100 or 24	40
EMA-0375	15	30	3.797	2.563	4.047	.25	3/4 or 7/8	3/16 x 3/32	100 or 24	40
EMA-0425	35	70	4.359	2.75	4.625	.25	1 or 1 1/8	3/16 x 3/32	100 or 24	40
EMA-0475	75	150	4.828	3.063	5.188	.313	1 1/4 or 1 3/8	1/4 x 1/8	100 or 24	50
EMA-0625	150	300	6.359	3.625	6.75	.375	1 3/4 or 1 7/8	3/8 x 3/16	100 or 24	50
EMA-0800	300	600	8.094	4.063	8.5	.375	2 or 2 1/4	7/16 x 7/32	100 or 24	80
EMA-0950	600	1200	9.641	4.438	10.063	.375	2 3/4 or 3	9/16 x 9/32	100 or 24	90
EMA-1150	1200	2400	11.5	5.063	11.813	.375	3 1/4 or 3 1/2	3/4 x 3/8	100 or 24	100

* All clutch coils will operate at rated voltage + 10%. Standard lead length is 73", special voltage available.

TECHNICAL DATA SHEET D9599 AVAILABLE MODEL EMA CLUTCH CUPS: These standard, hardened clutch cups are designed especially for use with Model EMA Maxitorq Electric Clutches. They are available with internal or external flange and are provided with mounting bolt holes. They are easily adaptable to various types of driven or driving members.

Internal Flange

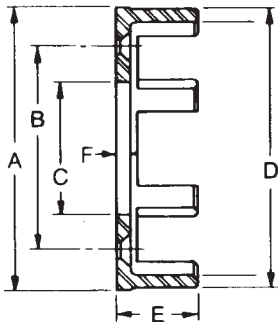

DRIVE CUP #	A	B (b.c.)	Screw Size	# of Holes	C	D	E	F	# OF SLOTS
EMA-0265-106-30	2.787 2.785	1.880 1.870	10	3	1.377 1.375	2.625	.989	.188	8
EMA-0325-106-30	3.526 3.560	2.567 2.557	1/4	3	1.877 1.875	3.5	1.063	.188	8
EMA-0375-106-30	4.250 4.248	3.067 3.057	1/4	3	2.017 2.015	4.188	1.188	.188	8
EMA-0425-106-30	4.750 4.748	3.630 3.620	1/4	3	2.517 2.515	4.688	1.25	.188	8
EMA-0475-106-30	5.250 5.248	3.942 3.932	5/16	3	2.517 2.515	5.188	1.375	.25	8
EMA-0625-106-30	6.812 6.810	5.317 5.307	3/8	4	3.767 3.765	6.75	1.656	.313	8
EMA-0800-106-30	8.562 8.560	6.255 6.245	1/2	4	4.517 4.515	8.5	1.703	.313	12
EMA-0950-106-30	10.062 10.060	8.067 8.057	1/2	4	5.517 5.515	10	1.781	.313	12
EMA-1150-106-30	11.812 11.809	9.817 9.807	1/2	6	8.017 8.015	11.75	2	.313	12

External Flange

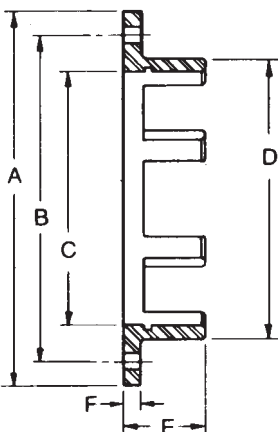

DRIVE CUP #	A	B (b.c.)	Screw Size	# of Holes	C	D	E	F	# OF SLOTS
EMA-0325-106-20	4.625 4.623	4.130 4.120	1/4	3	3.300 3.298	3.5	1.063	.25	8
EMA-0375-106-20	5.625 5.623	4.880 4.870	1/4	3	3.814 3.812	4.188	1.188	.25	8
EMA-0425-106-20	6.125 6.123	5.380 5.370	1/4	4	4.314 4.312	4.688	1.25	.25	8
EMA-0475-106-20	6.875 6.873	6.005 5.995	5/16	4	4.814 4.812	5.188	1.375	.25	8
EMA-0625-106-20	8.500 8.498	7.692 7.682	3/8	4	6.377 6.375	6.75	1.656	.313	8
EMA-0800-106-20	10.625 10.623	9.630 9.620	1/2	4	8.095 8.093	8.5	1.781	.313	12
EMA-0950-106-20	12.250 12.248	11.130 11.120	1/2	4	9.533 9.531	10	1.781	.313	12
EMA-1150-106-20	14.250 14.247	13.005 12.995	1/2	6	11.253 11.250	11.75	2	.375	12

Note: External Flange Cup for Model EMA 0265 available upon request.



291 Boston Turnpike, P.O. Box 9546, Bolton, CT 06043
 Tel: 860-643-1531 • Fax: 860-646-2645 • email: maxitorq@cjmco.com
 Toll Free: 888-629-4867